

LINE FOR PRODUCTION OF LATOFLEX BATTEN

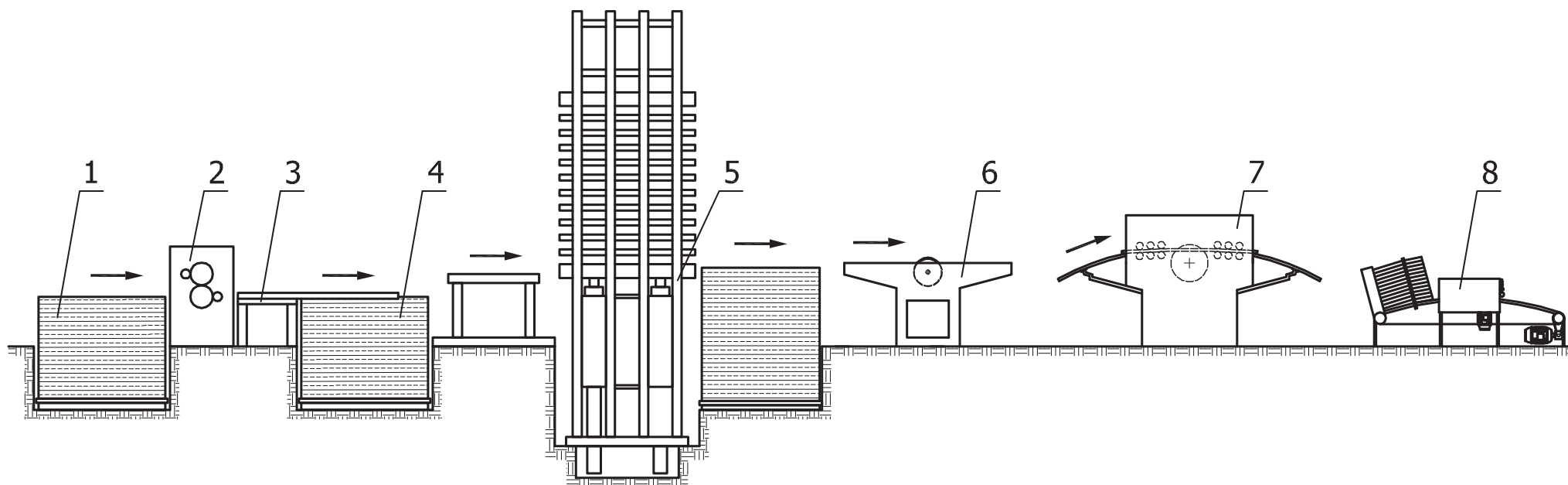

1. Lifting table
2. Device for glue spreading
3. Plate conveyor
4. Stacking table
5. Several day-opening warm press
6. Two-sided marker
7. Cutter (several blades)
8. Two-sided mill

Purpose: Production of latoflex batten

Main technical characteristics:

Heating plate size	2200 x 1400 [mm]	On request
Size of finished batten	2000 x 1200 [mm]	
Specific pressing pressure	max 240 [N/cm ²]	
...	...	